



RV GenSet

- Perfect for Travel Trailers
- Microprocessor Control with Diagnostics
- Sealed Connectors
- 3-Year Limited Warranty
- Lightweight, Compact
- Overhead Valve Engine for Efficiency, No Decarboning
- Quieter than National Park Sound Level Standards

Ratings and Models

Model	Fuel	Hz	RPM	Watts	Voltage	Amps	Phase	Circuit Breaker
4.0 KYD-3269	Gasoline	60	3600	4000	120	33.3	1	30A, 1-pole
3.6 KYD-3270	LP	60	3600	3600	120	30.0	1	30A, 1-pole
3.6 KYD-3271	Gasoline	50	3000	3600	230(1,2)	15.7	1	17A, 2-pole
3.3 KYD-3272	LP	50	3000	3300	230(1,2)	14.3	1	17A, 2-pole

(1) Adjustable 220-240, (2) Reconnectable to 110/250 or 120/240

Ratings apply to altitudes up to 500 ft (152.4 m), 85°F (29.4°C).

Derating: Power output will decrease 3.5% for each 1,000 ft (305 m) above sea level and 1% for each 10°F (5.5°C) increase in ambient temperature above 85°F (29°C).

Weight, Size and Sound Level

- **Weight:** 167 lb
- **Size:** Length 25.7 in (654 mm), Width 19.7 in (500.4 mm), Height 14.4 in. (353.1 mm)
- **Sound*:** 60 Hz 70 dB(A) @ 10 ft (3 m), 1/2 Load

*Typical RV installation

Standard Features

- Microprocessor control with digital voltage regulator
- Starter overcrank protection
- Generator field overload protection
- Over/under frequency protection
- Over/under voltage protection
- Loss of AC sense protection
- Mechanical fault protection
- Detects starter faults
- Reverse connections and high battery voltage protection
- 4-point vibration isolator mounting system
- Magnetic circuit breaker
- Automatic resetting of DC circuit overcurrent protection for set wiring and remote start wiring
- Integral enclosure cover and steel base
- High stability mechanical governor
- Sealed remote start connector
- Automotive-type starter with automatic start disconnect
- Fuel filter
- Electric magneto ignition
- USDA Forest Service-approved, spark-arresting muffler kit available
- Cross-flow pressure cooling
- Automatic choke
- Electric fuel pump with positive fuel safety shutoff (gasoline)
- Electric fuel shutoff solenoid (LPG)
- 125 in. (3.2 m) generator output leads
- Intake silencer, sound deadening material and baffles reduce sound level
- Start-stop/prime rocker switch on control with LED status indicator light for set diagnostics

Engine Detail

Model: Onan E095H

Design: 4-cycle, overhead valve, single horizontal cylinder

Displacement: 18.5 in³ (304 cm³)

Compression Ratio: 8.5:1

Maximum Power at 60 Hz

LPG - 8.6 bhp (6.4 kW)

Gasoline - 9.5 bhp (7 kW)

Maximum Power at 50 Hz

LPG - 7.6 bhp (5.7 kW)

Gasoline - 8.3 bhp (6.2 kW)

Cooling: Cross Flow Air - Pressure Type

Cooling Air Volume:

60 Hz: - 300 ft³/min (8.5 m³/min)

50 Hz: - 250 ft³/min (7.1 m³/min)

Combustion Air Volume:

60 Hz: 19 ft³/min (0.5m³/min)

50 Hz: 16 ft³/min (0.45m³/min)

Average Fuel Consumption:

Gasoline

	No Load		Half Load		Full Load	
	gph	l/h	gph	l/h	gph	l/h
60 Hz 4.0 KYD	0.3	1.1	0.5	1.8	0.7	2.7
50 Hz 3.6 KYD	0.2	0.8	0.4	1.4	0.6	2.2

LPG

	No Load			Half Load			Full Load		
	gal/h	lb/h	kg/h	gal/h	lb/h	kg/h	gal/h	lb/h	kg/h
60 Hz 3.6 KYD	0.4	1.5	0.7	0.6	2.4	1.1	0.7	3.1	1.4
50 Hz 3.3 KYD	0.3	1.1	0.5	0.5	2.2	1.0	0.7	2.9	1.3

Sidedraft Carburetor: KY (Gasoline)

Electric Fuel Pump: Positive fuel shutoff (3 psi), fuel lift 3 ft (914 mm)

Air Cleaner: Replaceable dry element
Patented automatic choke

Vapor Withdrawal System with Demand Regulator: KY (LPG)

Ignition System: Electronic magneto type

Starting System: Remote, 12 V, 3-wire negative ground

Starter: Automotive type with environmentally protected pinion; automatic start disconnect

Lubrication: Splash lubrication

Oil Capacity: 1.6 qt. (1.5 L)

Cylinder-Crankcase: Aluminum alloy with iron cylinder liner cast into the block, aluminum alloy oil base

Cylinder Head: Aluminum, valves in head, removable

Generator Detail

Design: Onan, revolving field, AC, 2-pole self-excited. Permanently aligned to engine by a tapered shaft. Drip-proof construction.

Insulation System and Temperature Rise: Meets ANSI/RVIA-EGS-1-1998, BS-4999, and CSA Bulletin 946 standards.

Cooling: Direct drive centrifugal blower. Air required; includes engine cooling air volume:

60-Hz: 300 ft³/min (8.5 m³/min)

50 Hz: 250 ft³/min (7.1 m³/min)

Cast aluminum housing for excellent heat transfer

Voltage Regulation: Microprocessor control with digital voltage regulator.

Rotor: Laminated electrical steel assembly press fitted to shaft, balanced. Heavy insulated copper wire windings. Amortisseur windings for improved waveform and motor starting.

Stator: Laminated electrical steel assembly. Heavy insulated copper wire windings.

DC Brushes: Electrographic; long life

Bearing: Double-sealed, prelubricated ball bearing

GenSet Performance

Air Conditioner Starting: (60 Hz - Gasoline) One 13500 BTU air conditioner with 2000-watt baseload at 500 ft (152.4 m) and 100° F (38° C).

Frequency and Voltage Regulation: Exceeds requirements of ANSI/RVIA EGS-1- 1998.

Basic Dimensions

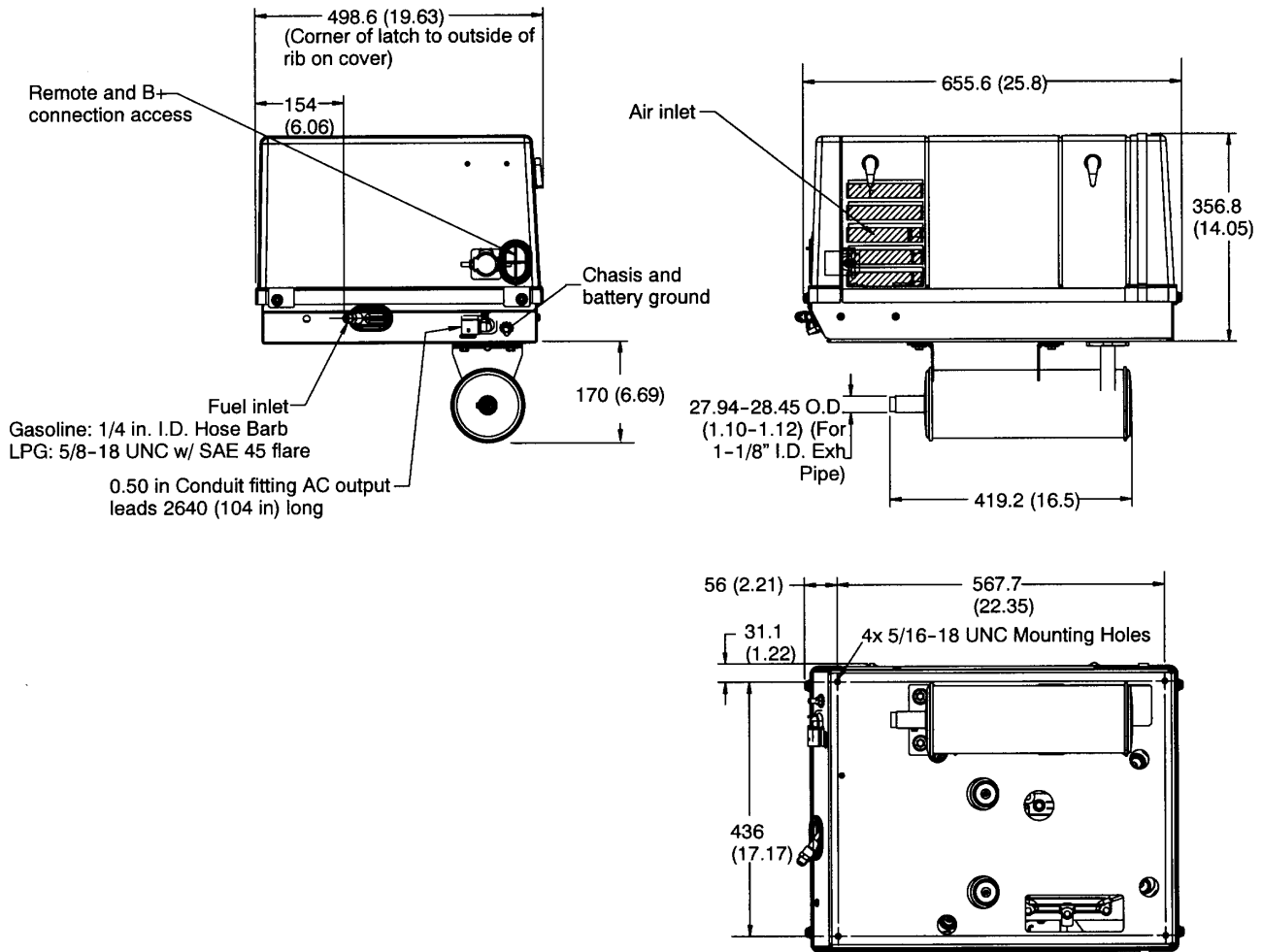

CAUTION: Drawing 500-3717 is supplied for reference only and should not be used for design or installation.

Options and Accessories

- Muffler kit with USDA Forest Service approved spark arrestor (541-0916)
- Underfloor mounting kit (P/N 541-0938) bolts through floor
- Underfloor mount template (P/N 539-4815) for use with underfloor kit (P/N 541-0938)
- End mount bracket kit available (P/N 541-0952)
- Template for compartment mount (P/N 539-4814)
- Remote control panel including start-stop/prime switch with status indicator light (P/N 300-5331)
- Remote control panel including start-stop/prime switch with status indicator light and hourmeter (P/N 300-5332)
- Remote control panel including start-stop/prime switch with status indicator light and DC voltmeter (P/N 300-5333)
- Remote control pigtail adapter (P/N 300-4946)
- Remote control plug and wire harness (10 ft. - P/N 338-3489-01, 30 ft. - P/N 338-3489-02)

Onan Testing for RV Application

Tested at extremes of temperature -20° F (-29° C) to 120° F (49° C) for starting and operation.
Tested with RV loads, air conditioners, microwaves, converter, TVs, VCRs.
Tested installed. Onan owns RVs used for product development testing.
Tested in high humidity conditions.
Tested in salt spray conditions.
Tested in heavy airborne dust conditions.
Field Test program.
60 Hz (120V only) models listed by SGS United States Testing Company, Inc. per ANSI/EGS-1 and CSA-certified per Electrical Bulletin 946.
Ratings apply to altitudes up to 500 ft (150 m), 85° F (29° C) ambient with muffler, in RV enclosure.
60 Hz models meet U.S. EPA and California emissions standards.



Operating Temperature Range

Gasoline sets will operate from -20°F (-29°C) to 120°F (49°C). LPG sets will operate from 0°F (-18°C) to 120°F (49°C). LPG set starting and operation below 32°F (0°C) depends upon LP tank capacity, surface area and butane content of LPG.

Warranty Policy

The Limited Warranty covers virtually everything except routine maintenance for the first two years you own your RV generator, and covers parts and labor on major power train and generator parts during the third year. In addition, it also includes a free 90-day adjustment policy, which provides that Onan will make minor adjustments to your new unit during the first three months you own it - free of charge! Please note: The Onan 3-year Limited Warranty applies to RV generators used in RV applications only, and does not apply to RV generators used in commercial mobile applications.

For complete Onan Limited Warranty details see your Cummins Power Generation Distributor or Onan Certified RV Service and Parts Dealer.

After Sale Support

GENUINE ONAN MAINTENANCE CARE PARTS AND PRODUCTS

For your ongoing satisfaction and the dependability of your Onan RV generator, Onan offers a complete line of replacement and tune-up parts, oil and maintenance chemicals specifically designed for RV generator. Available at Onan Certified RV Service and Parts Dealers coast-to-coast, Green Label Parts™ are packaged for correct selection and convenient on-board storage.

EASY TO LOCATE CERTIFIED ONAN RV SERVICE AND PARTS DEALERS

Onan has trained, tested and certified over 1,000 Service and Parts Dealers covering most major metropolitan areas in the U.S. and Canada. To easily locate Dealer, no matter where you travel, call 1-800-888-ONAN or use the dealer locator on www.onan.com.



See Your Distributor for More Information:



Cummins Power Generation
1400 73rd Avenue N.E.
Minneapolis, MN 55432
763.574.5000
1-800-888-ONAN
Fax 763.574.8289
www.onan.com

Cummins Power Generation is a subsidiary of Cummins Inc.
Onan is a Registered Trademark of Cummins Inc.

WARNING: Backfeed to a utility system can cause electrocution and/or property damage. Do not connect to any building electrical except through an approved device or after building main breaker is open.

