



# RV Marquis Platinum™ 7000 EFI GenSet



## RV GenSet

- **Electronic Fuel Injection - Industry First for Maximum Performance**
- **Quietest GenSet in Its Class**
- **Exceptionally Low Vibration Levels**
- **Integrated Design with Enclosed Muffler for Easy Installation**
- **Self-Diagnostic Capability to Simplify Troubleshooting**
- **Runs Two Air Conditioners with Power to Spare**
- **Digital Voltage Regulations for Stability as Appliance Loads Change**
- **3-Year Limited Warranty, Lifetime Drive Warranty**

## Ratings and Models

Model	Fuel	Hz	RPM	Watts	Voltage	Amps	Ph	Circuit Breaker
7 HGJAA-97	Gasoline	60	2880	7000	120	58.3	1	(2) 30A
7 HGJAA-1276	Gasoline	60	2880	7000	120	58.3	1	(1) 30A, (1) 20A HACR

Ratings apply to altitudes up to 3000 ft (914 m).

Derating: Power output will decrease 3.5% for each 1000 ft (305 m) above 3000 ft (914 m), temperature derate not required for temperatures under 120°F (49.2°C).

## Weight, Size and Sound Level

- **Weight:** 290 lbs (132 kg)
- **Size:** Length: 33.6 in (853 mm), Width: 22.2 in (563 mm), Height: 16.7 in (425 mm)
- **Sound:** Readings at 10 ft (3 m) half load: 64 dB(A)

## Standard Features

- Electronic Fuel Injection (EFI) for clean, smooth running under all conditions
- Maintenance-free electronic governor
- Onan Performer™ OHV engine
- Pressurized Thru Flow cooling system
- 4-point mounting system with vibration isolators
- Universal mounting tray with structural capability to support the genset in RV applications
- Integral USDA Forest Service-approved spark-arrestor muffler
- Replaceable dry element air cleaner
- Integral control box
- Instant One-Touch stop switch
- Electronic ignition
- Enclosed muffler
- Sound-attenuated housing
- Remote waterproof connector
- Automotive type starter with automatic start disconnect
- Long-life fuel filter
- Spin-on, full-flow oil filter
- Low oil pressure protection
- Overspeed/underspeed protection
- Overcurrent protectors (see Models and Ratings section)
- Low power factor field overcurrent protection
- 120-inch generator output leads
- Digital voltage regulation
- 2-inch exhaust tube, straight with flanged end

## Engine Detail

**Model:** Onan Performer™ OHV EH65V gasoline engine  
**Design:** 4-cycle, OHV, 90-degree V-Twin  
**Compression Ratio:** 8:1  
**Displacement:** 39.8 in<sup>3</sup> (653 cm<sup>3</sup>)  
**Maximum Power:** 12.3 bhp (9.2 kW)  
**Cooling:** Centrifugal blower, generator-mounted for high effectiveness, pressurized system, vertical flow  
**Cooling Air Volume:** 500 ft<sup>3</sup>/min (14.2 m<sup>3</sup>/min). Includes engine, generator control cooling air flow  
**Fuel System:** Digitally controlled, electronic fuel injection  
 - Combustion air volume at rated load: 18.8 ft<sup>3</sup>/min (0.53 m<sup>3</sup>/min)  
 - Electronically controlled throttle body governor regulation  
 - Coach chassis-mounted, rotary roller vane pump  
 - Replaceable dry element air cleaner

### Average Fuel Consumption:

Gasoline	No Load		Half Load		Full Load	
	gal/h	l/h	gal/h	l/h	gal/h	l/h
60 Hz	0.4	1.6	0.7	2.7	1.1	4.3

**Ignition System:** Electronic magneto type with resistor plugs  
**Starting System:** Remote, 12 V, negative ground. Automotive type starter with steel pinion and ring gear, automatic start disconnect, connector for remote start cable, start-stop rocker switch mounted on set control  
**Lubrication:** Full pressure positive displacement lube oil pump, spin-on, full flow lube oil filter, low oil pressure shutdown, dipstick  
**Oil Capacity:** 2.0 qt (1.9 L) including filter  
**Cylinder-Crankcase:** Alloy aluminum with iron cylinder liners cast into the block, aluminum oil base  
**Cylinder Head:** Aluminum, overhead valve, removable

## Generator Detail

**Design:** Onan, revolving field, AC, 2-pole self-excited, two bearing design  
**Insulation System and Temperature Rise:** Meets ANSI/RVIA EGS-1, and CSA 946 requirements  
**Cooling:** Direct drive centrifugal blower, cast aluminum housing for excellent heat transfer  
**Excitation:** Capped, digital voltage regulation

**Rotor:** Laminated electrical steel assembly press-fitted to shaft, balanced. Heavy insulated copper wire windings. Optimized air gap for improved waveform and motor starting.  
**Stator:** Laminated electrical steel assembly, skewed for improved waveform. Heavy insulated copper wire windings  
**DC Brushes:** Electrographic; long life  
**Bearing:** Double-sealed prelubricated ball bearings

## Generator Set Performance

**Air Conditioner Starting:** Two 13500 BTU air conditioners with 3500-watt baseload at 100°F (38°C) at 500 ft (152 m) elevation.

**Frequency and Voltage Regulation:** No load to full load: 0%

## Basic Dimensions

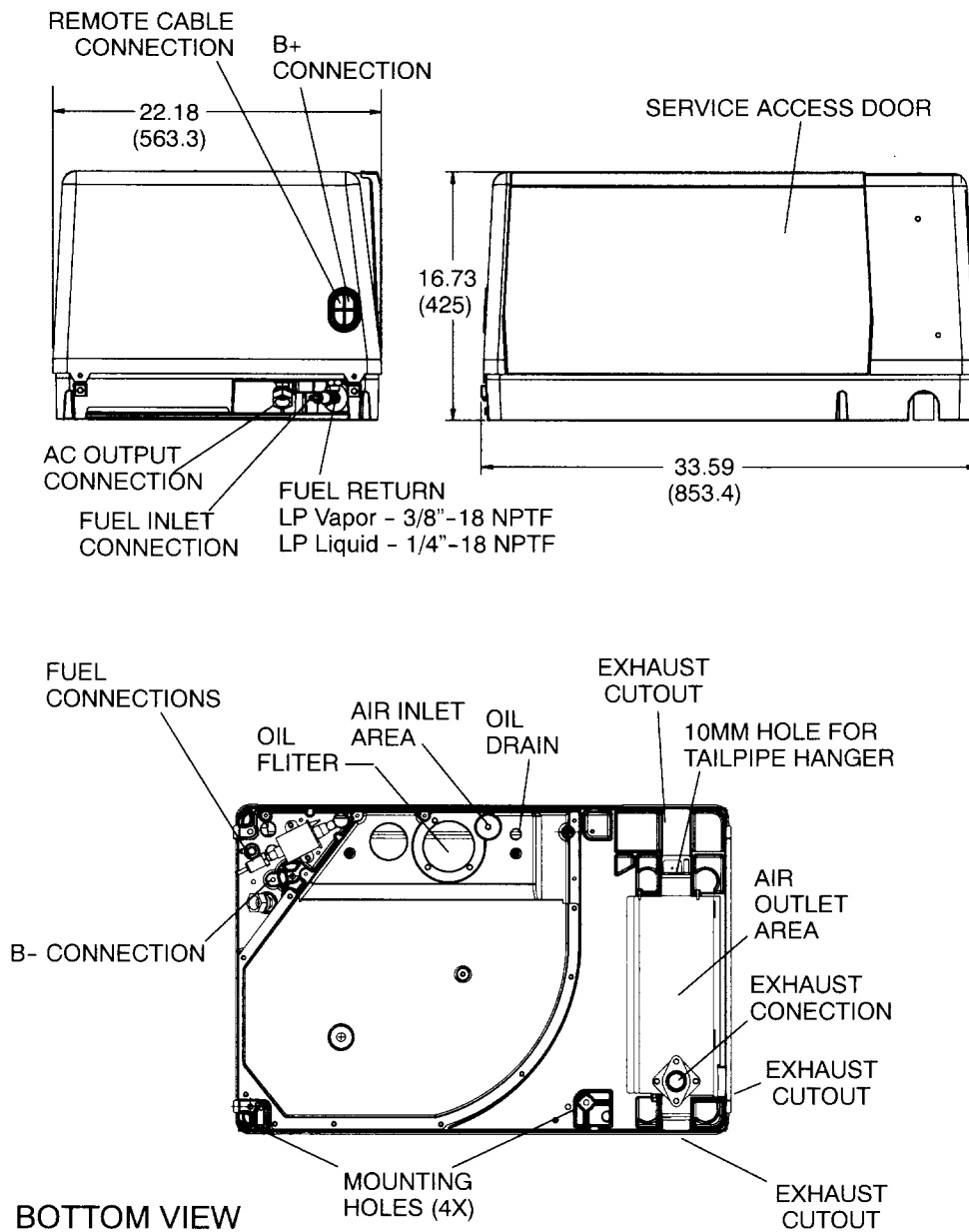

CAUTION: Drawings are supplied for reference only and should not be used for installation. See Installation Manual for details.

## Options and Accessories

- Remote start/stop rocker switch (P/N 300-5331)
- Remote control with start/stop switch and running time meter (P/N 300-5332)
- Remote control w/start/stop switch and DC voltmeter (P/N 300-5333)
- Remote control plug and wire harness (10 ft - P/N 338-3489-01, 30 ft - P/N 338-3489-02)
- Battery, 12 V, 360 cold cranking amps at 0°F (-18°C)
- Underfloor mount kit (P/N 405-6699)
- Installation template (P/N 539-2057)
- Tailpipe kit (22 in - P/N 155-3481-01, 26 in - 155-3481-02)
- Exhaust tube, straight with flanged end (3 in - P/N 155-2610, 7 in - P/N 155-2424, 12.5 in - P/N 155-2610-01)
- Required
- Fuel pump kit (P/N 541-1002)

## Onan Testing for RV Application

Tested at extremes of temperature -20 o F (-29 o C) to 120 o F (49 o C) for starting and operation.  
Tested with RV loads, air conditioners, microwaves, converter, TVs, VCRs.  
Tested installed. Onan owns RVs used for product development testing.  
Tested in high humidity conditions.  
Tested in salt spray conditions.  
Tested in heavy airborne dust conditions.  
Field Test program.  
60 Hz (120V only) models listed by SGS United States Testing Company, Inc. per ANSI/EGS-1 and CSA-certified  
per Electrical Bulletin 946.  
Ratings apply to altitudes up to 500 ft (150 m), 85 o F (29 o C) ambient with muffler, in RV enclosure.  
60 Hz models meet U.S. EPA and California emissions standards.



## Operating Temperature Range

Gasoline sets will operate from -20°F (-29°C) to 120°F (49°C). LPG sets will operate from 0°F (-18°C) to 120°F (49°C). LPG set starting and operation below 32°F (0°C) depends upon LP tank capacity, surface area and butane content of LPG.

## Warranty Policy

The ONAN Limited Warranty covers virtually everything except routine maintenance for the first two years you own your RV generator set, and covers parts and labor on major power train and generator set parts during the third year. In addition, it also includes a free 90-day adjustment policy, which provides that Onan will make minor adjustments to your new genset during the first three months you own it - free of charge! Please note: The Onan 3-year Limited Warranty applies to RV generators used in RV applications only, and does not apply to RV generators used in commercial mobile applications.

The warranty period for the drive train belt and pulleys on the HGJ series generators used in recreational vehicles shall be the life of the generator. For the original owner, this drive train warranty shall include parts and labor. For succeeding owners, this power train warranty shall cover belt and pulley parts only.

For complete Onan Limited Warranty details see your Onan Distributor or Certified Onan Service Dealer.

## After Sale Support

### GENUINE ONAN MAINTENANCE CARE PARTS AND PRODUCTS

For your ongoing satisfaction and the dependability of your Onan RV genset, Onan offers a complete line of replacement and tune-up parts, oil and maintenance chemicals specifically designed for RV gensets. Easy to find at certified Onan RV Service and Parts Dealers coast-to-coast, Onan Green Label™ RV parts are packaged for correct selection and convenient on-board storage.

### EASY TO LOCATE CERTIFIED ONAN RV SERVICE AND PARTS DEALERS

Onan has trained, tested and certified over 1,000 Onan RV Service Dealers covering most major metropolitan areas in the U.S. and Canada. To easily locate the certified Onan Service Dealer, no matter where you travel, call 1-800-888-ONAN and ask us to send you an RV Service and Parts Dealer Directory (F-919) or visit [www.onan.com](http://www.onan.com).



## See your distributor for more information:



Cummins Power Generation  
1400 73rd Avenue N.E.  
Minneapolis, MN 55432  
763.574.5000 ·  
1-800-888-ONAN ·  
Fax 763.574.8289 ·  
[www.onan.com](http://www.onan.com)

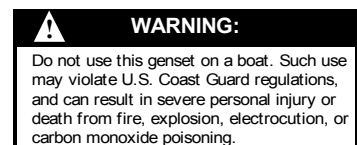

Cummins Power Generation is a subsidiary of Cummins Inc. Onan is a registered trademark of Cummins Inc.

**WARNING:** Backfeed to a utility system can cause electrocution and/or property damage. Do not connect to any building electrical except through an approved device or after building main breaker is open.